

1PZP9N

DESCRIZIONE Piano cottura ZERO plus con cappa integrata
DESCRIPTION ZERO plus hob with integrated hood

PESO LORDO 42 Kg
GROSS WEIGHT

DIMENSIONI IMBALLO 820x1020x520 mm
PACKAGING DIMENSIONS

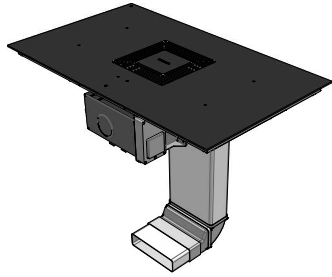

INDUZIONE (INDUCTION)

- Comandi: Touch Control (Touch Control)
- Funzioni: Chef Cook, Bridge, Booster, timer di fine cottura 1-600', limitatore di potenza, riconoscimento, automatico pentole, rilevamento selettivo pentole, funzione pausa/riciama, minute minder, preriscaldamento automatico, mantenimento calore.
(Function: Chef Cook, Bridge, Booster, cooking end timer 1-600', power management, automatic pots recognition, selective pots detection, pause/recall function, minute minder, automatic preheating, heat retention)
- Dispositivi di sicurezza: blocco elettronico funzioni per la sicurezza bambini, spia calore residuo allarme traboccamento, spegnimento di sicurezza
(Safety devices: electronic child safety block, residual heat indicator, overflow alarm, safety switch-off)
- Diametro pentola minimo: Ø 110 mm (Minimum pot diameter: Ø 110 mm)
- Livelli di potenza regolabili: 1,4 - 1,5 ... 7,3 - 7,4 kW (Power management: 1,4 - 1,5 ... 7,3 - 7,4 kW)
- Potenza massima assorbita: 7,4 kW (Maximum absorbed power: 7,4 kW)
- Potenza zone induzione: 4 zone Octa 2,1-3 Kw(*) (Induction zone power: 4 Octa zone 2,1-3 Kw(*)
- (*) in funzione booster (In booster function)
- Incasso: 83x47,5 cm (83x47,5 cm cut-out)

CAPPA (HOOD)

- Velocità: 3 + intensiva (Speed: 3 + intensive speed)
- Portata nominale: 800 m³/h (Engine flow: 800 m³/h)
- Portata Booster: 596 m³/h (Booster flow: 596 m³/h)
- Pressione: 524 Pa (Pressure: 524 Pa)
- Rumorosità: 56-76 Lw (dBA) (Noisiness: 56-76 Lw[dBA])
- Filtro: acciaio inox AISI 304 (Filter: Stainless steel)
- Classe energetica: A++ (Energetic class: A++)
- Potenza massima assorbita: 0,22 kW (Maximum absorbed power: 0,22 kW)
- Aspirazione filtrante opzionale (Optional filter extraction)
- Altezza minima zoccolo: 60 mm (minimum kitchen plinth height: 60 mm)

Per maggiori dettagli consultare il manuale d'uso
 (For more detail see the user manual)

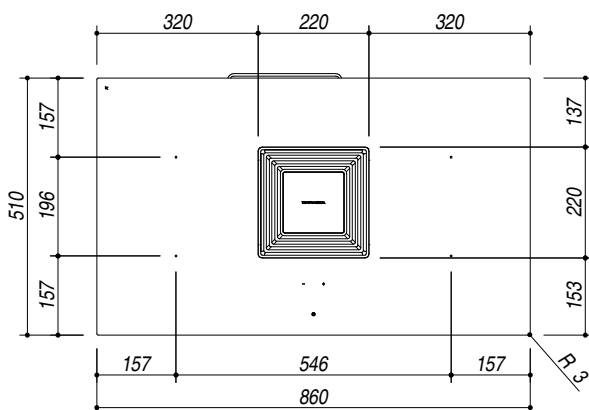
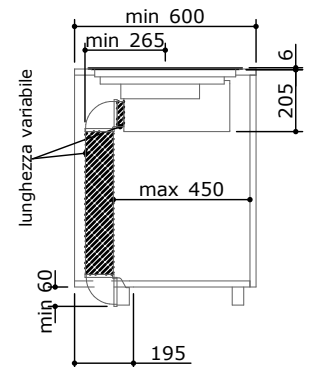
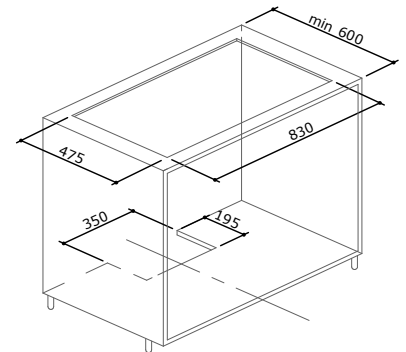
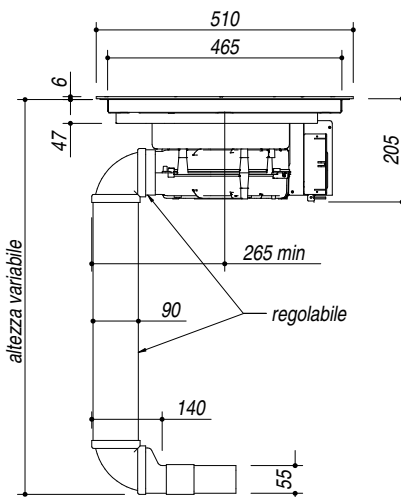
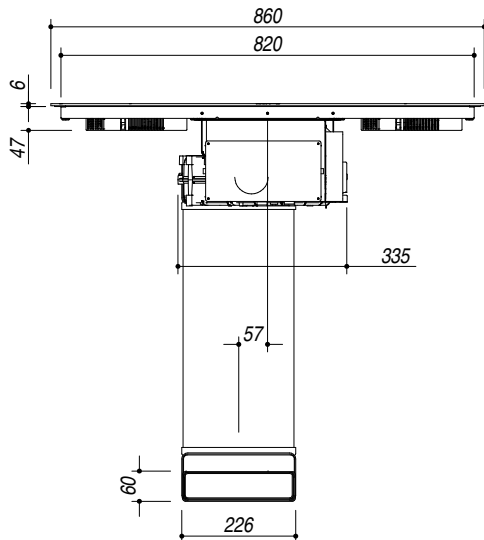

FORATURA PER INSTALLAZIONE FILOTOP FLUSH CUTOUT FOR TOP

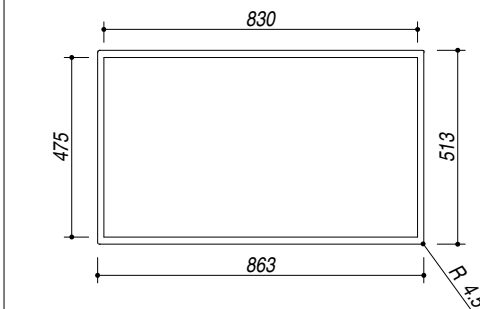

ABBASSAMENTO LOWERING

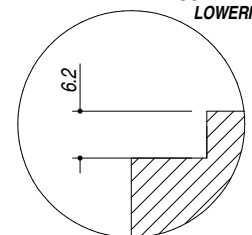

SCALA DISEGNO
 DRAWING SCALE 1:15



TUTTE LE MISURE IN mm
 ALL MEASURES IN mm

TOLLERANZA LINEARE: ± 0.5 mm
 LINEAR TOLERANCE

TOLLERANZA ANGOLARE: ± 0.2 °
 ANGULAR TOLERANCE