

MOON ISLAND

ELICA DESIGN CENTER

90x57 - 120x57 - 175x73 cm

Aspirante Duct-out - Filtrante Filtering (180cm)

Acciaio Inox
Stainless steel



LONG LIFE
FILTER



CM 50



CM 65



Ø150



ENERGY
CLASS
(A+++/D)

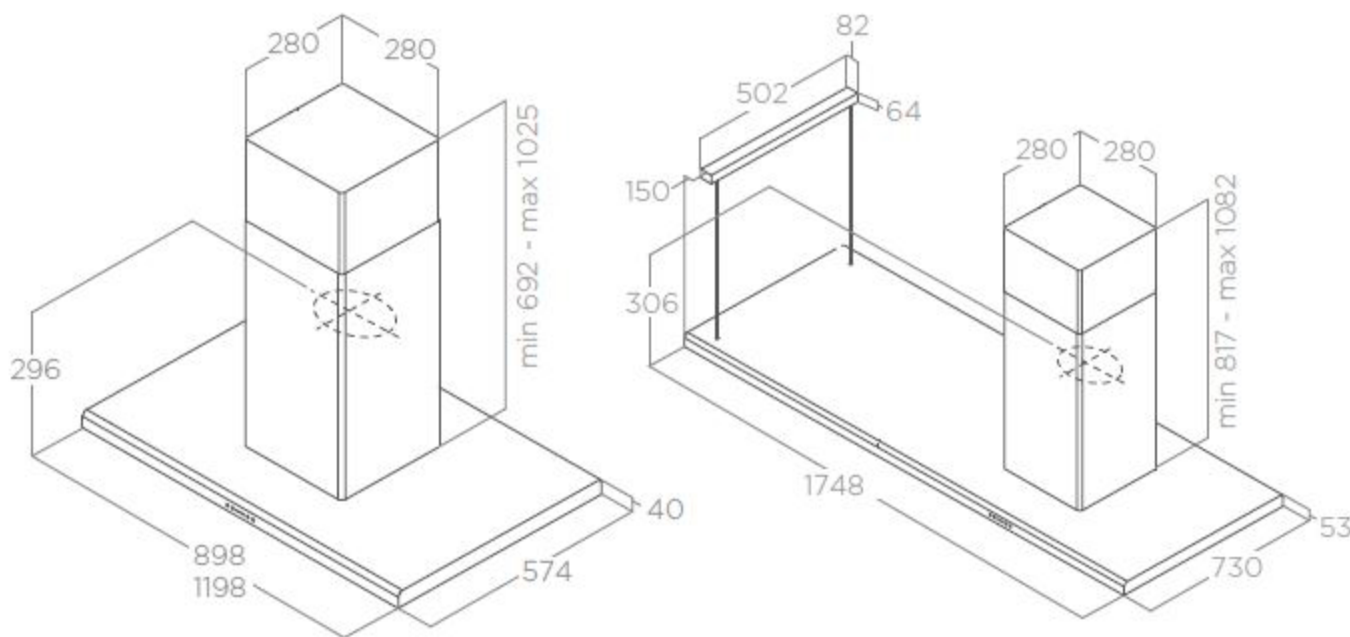

ILLUMINAZIONE LIGHTING

Tipo Type	Neon 2x21 W (90cm) - Neon 2x28 W (120cm) - Neon 4x21 W (180cm)
Intensità Intensity	172 (90cm) - 230 (120cm) - 176 (180cm) LUX
Temperatura Temperature	6500 K

PERFORMANCE PERFORMANCE

Comandi Controls	Pulsantiera elettronica 3V+I 3S+B Electronic push button
Portata intensiva Booster airflow	690 m ³ /h
Livello sonoro min-max Noise level min-max	52 - 68 db(A)
Assorbimento totale Total absorption	302 (90cm) W - 316 (120cm) W 344 (180cm) W

Filtro grassi alluminio incluso Grease aluminium Filter included
Filtro carbone incluso (180cm) Charcoal filter included (180cm)
Camino incluso Chimney included

ACCESSORI ACCESSORIES

Filtro carbone Charcoal filter	CFC0141529A
Filtro carbone rigenerabile Regenerable charcoal filter	CFC0141725A

MODELLI MODELS

MOON ISLAND IX/F/180

PRF0079552A