

1PZA8N

DESCRIZIONE Piano cottura ZERO ADVANCE con cappa integrata
DESCRIPTION Zero Advance induction hob with integrated hood

PESO LORDO 26 Kg
GROSS WEIGHT

DIMENSIONI IMBALLO 1100x710x340 mm
PACKAGING DIMENSIONS

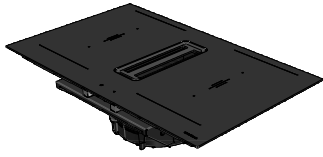

INDUZIONE (INDUCTION)

- Comandi: Touch Control (Touch Control)
- Funzioni: limitatore di potenza, Bridge, riconoscimento automatico pentole, Booster, funzione pausa/riclama, timer di fine cottura 1-600', minute minder, preriscaldamento automatico, mantenimento calore.
 (Function: power management, Bridge, automatic pan recognition, Booster, selective pan detection, pause/reminder function, cooking end timer 1-600', minute minder, automatic preheating, keep warm)
- Dispositivi di sicurezza: blocco elettronico funzioni per la sicurezza bambini, spia calore residuo, allarme traboccamento, spegnimento di sicurezza.
 (Safety devices: electronic child safety block, residual heat indicator, overflow alarm, safety switch-off)
- Diametro pentola minimo: Ø 110 mm (Minimum pan diameter: Ø 110 mm)
- Livelli di potenza regolabili: 2.8 - 3.5 - 4.5 - 7.4 kW (Power management: 2.8 - 3.5 - 4.5 - 7.4 kW)
- Potenza massima assorbita: 7,4 kW (Maximum absorbed power: 7,4 kW)
- Potenza zone induzione: 4 zone Octa 2,1 - 3 (*) - 3,7 (**) kW (Induction zone power: 4 Octa zone 2,1 - 3 (*) - 3,7 (**) kW)
- (*) in funzione booster (with booster function)
- (**) in funzione Bridge (with bridge function)
- Incasso: 75x47,5 cm (built in cut-out: 75x47,5 cm)

CAPPA (HOOD)

- Velocità: 8 + 2 intensive (Speed: 8 + 2 intensive speeds)
- Modalità aspirazione automatica (automatic hood extraction)
- Portata nominale: 800 m³/h (Engine flow: 800 m³/h)
- Pressione: 497 Pa (Pressure: 497 Pa)
- Rumorosità: 63-69 Lw (dBA) (Noisiness: 63-69 Lw[dBA])
- Filtro: Alluminio nero (Filter: Black Aluminum)
- Classe energetica: A+ (Energetic class: A+)
- Potenza massima assorbita: 0,22 kW (Maximum absorbed power: 0,22 kW)
- Uscita fumi posteriore (rear outlet)
- Aspirazione filtrante opzionale (Optional filtering extraction)

Per maggiori dettagli consultare il manuale d'uso
 (For more detail see the user manual)

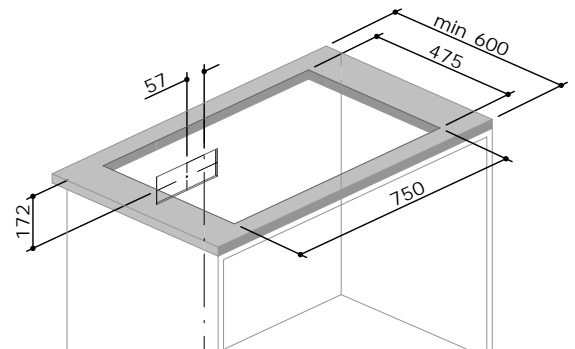
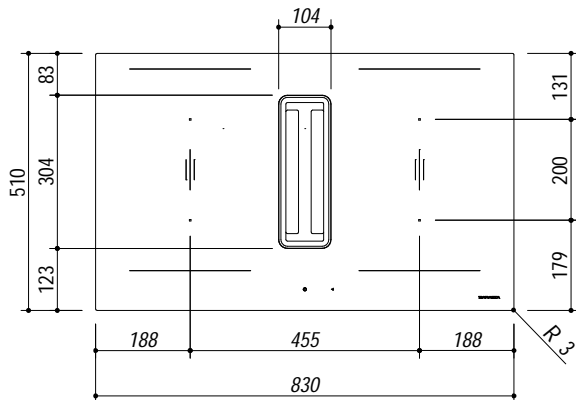
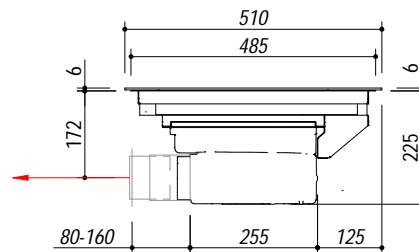
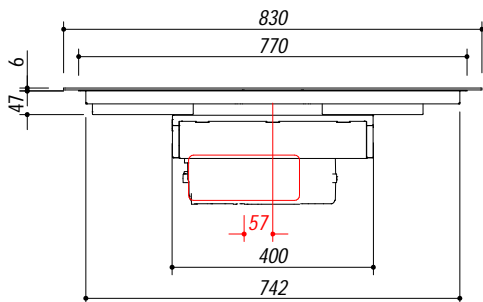

SCALA DISEGNO 1:15
DRAWING SCALE

TUTTE LE MISURE IN mm
ALL MEASURES IN mm

TOLLERANZA LINEARE: ± 0.5 mm
LINEAR TOLERANCE

TOLLERANZA ANGOLARE: ± 0.2 °
ANGULAR TOLERANCE

FORATURA PER INSTALLAZIONE AD INCASSO
BUILT-IN CUTOUT FOR TOP

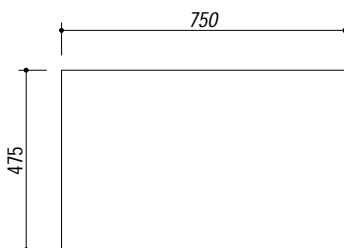

1:20

FORATURA PER INSTALLAZIONE A FILO
FLUSH CUTOUT FOR TOP

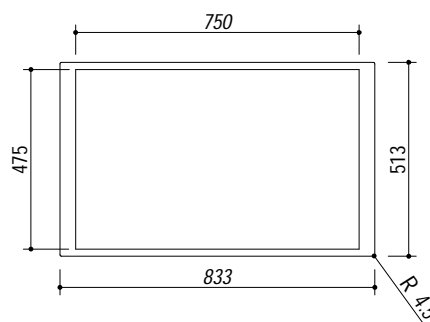

ABBASSAMENTO
LOWERING

